



# LED AREA LIGHTS

Delivering a new standard in engineering and superior lighting technology.

---

 **SATCO**® | **NUVO**®

# A NEW STANDARD IN AREA LIGHTING

**Our latest LED area lights are engineered to the highest standards for all outdoor area lighting applications!**

Built rugged using die cast aluminum and impact resistant lenses, these IP65 fixtures are all-weather tough. Offered in a type III, type IV, type V distribution from 100W-300W, in 4000K & 5000K and in two voltage packages; 120-277V & 277-480V, these area lights are built to meet a vast number of applications.



**TYPE III**  
**TYPE IV**  
**TYPE V**

The Type III, IV, and V distributions are designed for roadway, parking lots and other environments where a larger area of lighting is required.



# A FULL SUITE OF ACCESSORIES

**Enhance and optimize your lighting solutions with our full suite of accessories.**

Our comprehensive range of accessories such as slip-fitter, universal, yoke, and trunnion mounts, ensure flexibility for installations. Choose from our unique fixed arm or articulating extended slip-fitter mounts, which come with integrated junction boxes featuring sensor knockouts for hassle-free installations. Additionally, we offer a variety of sensors and controls, including photocells, PIR sensors, and microwave sensors, allowing you to customize and automate your lighting system. To address specific needs, we provide cutoff shields to eliminate light trespass and offer an additional 10kV surge protection accessory for added peace of mind.

**All area lights come standard with a 2<sup>3</sup>/<sub>8</sub>" slip-fitter mount.**



# Superior Lighting

**100W/150W**

LED Area Light  
Type III, IV, V

Bronze Powder Coated Finish  
for All Weather Durability

0-10V Dimming

Built-In 4kV Surge Protection

IP65 Rated

Operating Temperature  
-40C (-40F) to +45C (+113F)

50,000 Hours Life

5 Year Warranty



CERTIFIED





Scan the QR Code  
to view the Effective  
Projective Area Ratings.



## Dimensional

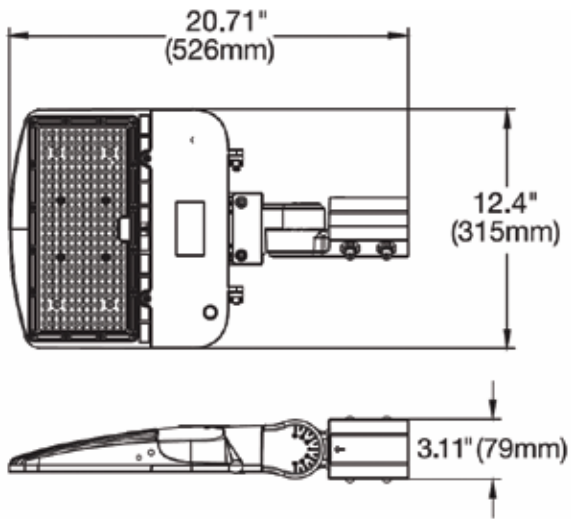

## Photocells, Sensors & Surge Suppression Accessories:

- **86/221:** Photocell For 120-277V Versions
- **86/223:** Photocell For 277-480V Versions
- **86/227:** PIR Sensor 120-277V
- **86/228:** MW Sensor 120-277V
- **86/226:** 12-24V PIR Sensor 277-480V
- **86/224:** 10kV Surge Suppressor 120-277V
- **86/225:** 10kV Surge Suppressor 277-480V

[For additional mounting options see page 12]



TYPE III	TYPE IV	TYPE V	W	V	CCT	EFFICACY	LM	DIMENSIONS
65/840	65/840/4	65/840/5	100W	120-277V	4000K	137.93 LPW	13793	L:20.71" W:12.40" H:3.11"
65/841	65/841/4	65/841/5	100W	120-277V	5000K	137.93 LPW	13793	L:20.71" W:12.40" H:3.11"
65/842	65/842/4	65/842/5	150W	120-277V	4000K	130.05 LPW	19507	L:20.71" W:12.40" H:3.11"
65/843	65/843/4	65/843/5	150W	120-277V	5000K	131.57 LPW	19736	L:20.71" W:12.40" H:3.11"
65/860	65/860/4	65/860/5	100W	277-480V	4000K	137.93 LPW	13793	L:20.71" W:12.40" H:3.11"
65/861	65/861/4	65/861/5	100W	277-480V	5000K	137.93 LPW	13793	L:20.71" W:12.40" H:3.11"
65/862	65/862/4	65/862/5	150W	277-480V	4000K	130.05 LPW	19507	L:20.71" W:12.40" H:3.11"
65/863	65/863/4	65/863/5	150W	277-480V	5000K	131.57 LPW	19736	L:20.71" W:12.40" H:3.11"



# Rugged Build

**200W**

LED Area Light  
Type III, IV, V

Bronze Powder Coated Finish  
for All Weather Durability

0-10V Dimming

Built-In 4kV Surge Protection

IP65 Rated

Operating Temperature  
-40C (-40F) to +45C (+113F)

50,000 Hours Life

5 Year Warranty



CERTIFIED



Scan the QR Code  
to view the Effective  
Projective Area Ratings.



## Dimensional

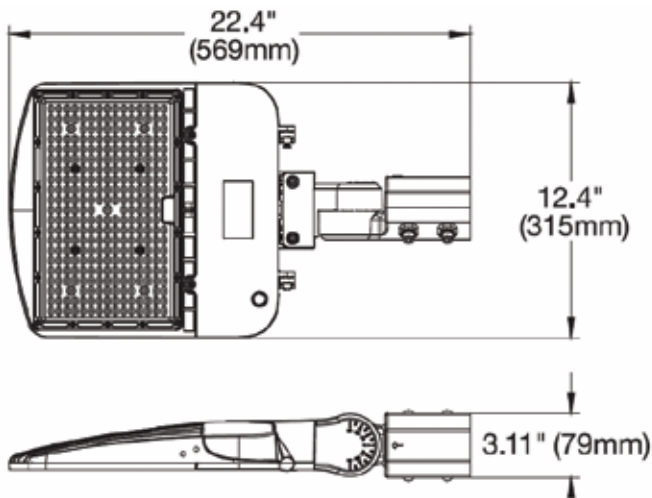

## Photocells, Sensors & Surge Suppression Accessories:

- **86/221:** Photocell For 120-277V Versions
- **86/223:** Photocell For 277-480V Versions
- **86/227:** PIR Sensor 120-277V
- **86/228:** MW Sensor 120-277V
- **86/226:** 12-24V PIR Sensor 277-480V
- **86/224:** 10kV Surge Suppressor 120-277V
- **86/225:** 10kV Surge Suppressor 277-480V

[For additional mounting options see page 12]



TYPE III	TYPE IV	TYPE V	W	V	CCT	EFFICACY	LM	DIMENSIONS
65/844	65/844/4	65/844/5	200W	120-277V	4000K	130.26 LPW	26051	L:22.40" W:14.40" H:3.11"
65/845	65/845/4	65/845/5	200W	120-277V	5000K	132.68 LPW	26536	L:22.40" W:14.40" H:3.11"
*65/864	*65/864/4	*65/864/5	200W	277-480V	4000K	130.26 LPW	26051	L:30.28" W:12.39" H:3.11"
*65/865	*65/865/4	*65/865/5	200W	277-480V	5000K	132.68 LPW	26536	L:30.28" W:12.39" H:3.11"

\* 277-480V 200W versions have the same footprint as the 240W & 300W to accommodate the larger drivers. See dimensional drawing on page 9.



# All-Weather Tough

**240W/300W**

LED Area Light  
Type III, IV, V

Bronze Powder Coated Finish  
for All Weather Durability

0-10V Dimming

Built-In 4kV Surge Protection

IP65 Rated

Operating Temperature  
-40C (-40F) to +45C (+113F)

50,000 Hours Life

5 Year Warranty





Scan the QR Code  
to view the Effective  
Projective Area Ratings.



## Dimensional

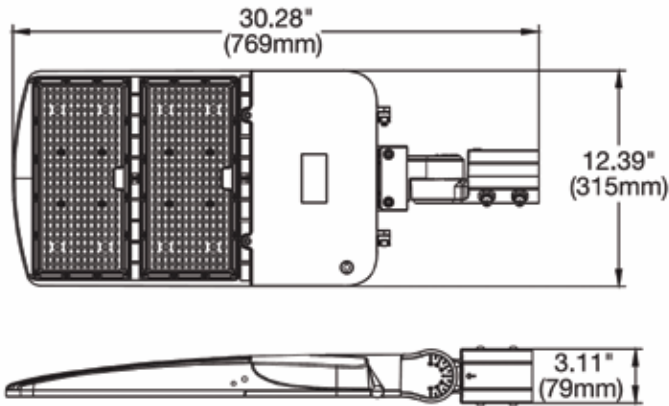

## Photocells, Sensors & Surge Suppression Accessories:

- **86/221:** Photocell For 120-277V Versions
- **86/223:** Photocell For 277-480V Versions
- **86/227:** PIR Sensor 120-277V
- **86/228:** MW Sensor 120-277V
- **86/226:** 12-24V PIR Sensor 277-480V
- **86/224:** 10kV Surge Suppressor 120-277V
- **86/225:** 10kV Surge Suppressor 277-480V

[For additional mounting options see page 12]



TYPE III	TYPE IV	TYPE V	W	V	CCT	EFFICACY	LM	DIMENSIONS
65/846	65/846/4	65/846/5	240W	120-277V	4000K	131.17 LPW	31481	L:30.28" W:12.39" H:3.11"
65/847	65/847/4	65/847/5	240W	120-277V	5000K	135.77 LPW	32585	L:30.28" W:12.39" H:3.11"
65/848	65/848/4	65/848/5	300W	120-277V	4000K	132.72 LPW	39815	L:30.28" W:12.39" H:3.11"
65/849	65/849/4	65/849/5	300W	120-277V	5000K	129.96 LPW	38988	L:30.28" W:12.39" H:3.11"
65/866	65/866/4	65/866/5	240W	277-480V	4000K	131.17 LPW	31481	L:30.28" W:12.39" H:3.11"
65/867	65/867/4	65/867/5	240W	277-480V	5000K	135.77 LPW	32585	L:30.28" W:12.39" H:3.11"
65/868	65/868/4	65/868/5	300W	277-480V	4000K	132.72 LPW	39815	L:30.28" W:12.39" H:3.11"
65/869	65/869/4	65/869/5	300W	277-480V	5000K	129.96 LPW	38988	L:30.28" W:12.39" H:3.11"



**Lumiled 2835R Chips** & Advanced Optics for Superior Performance

# Features

High-performance meets rugged, all-weather toughness in the design of these fixtures. They are constructed using high-quality materials such as Lumileds chips and Sosen drivers, ensuring durability and longevity. The design prioritizes advanced thermal consideration and heat dissipation, with integrated respirators to balance air pressure, integrated 4kV surge protection, and seismically tested for 3G vibrations.

To meet the requirements of various applications, these fixtures offer a comprehensive range of mounting accessories. They include innovative extended slip-fitter and fixed arm mounts with integrated junction boxes, as well as photocells, PIR & MW sensors, additional add-on surge suppression, and cutoff shields. With this versatile selection, these fixtures are suitable for any type III, type IV, or type V application, ensuring they can meet the specific needs of any project.

Advancedly engineered for maximum thermal dissipation to ensure long lasting life and performance.





## Integrated Respirator

Integrated respirators help to balance air pressure and prevent humidity build-up.



## Passive Heat-Sink

Finned, Heat-Sink Design allows for better performance and heat dissipation.



## Sensor Drill-Out

Fixtures are designed with a designated drill-out for simple sensor installations.



## Adjustable Mounting

An adjustable 2 3/8" slip-fitter mount comes standard with all units, allowing for up to 90° vertical articulation.



## Add-On Photocells

All fixtures come standard with a removable cover plate for a simple photocell installation.

**BUILT TOUGH WITH DIE-CAST CONSTRUCTION & HEAVY-DUTY  
HARDWARE TO WITHSTAND HARSH OUTDOOR ENVIRONMENTS**



# Mounting Options & Accessories

A comprehensive range of mounting accessories and add-on sensors are available to meet all mounting requirements.

**All fixtures include 2 3/8" Slip-Fitter Standard.**



Extended Slip-Fitter Mount  
with Sensor Knockouts  
65/875



Universal Mount with 2 3/8"  
Slip-Fitter Mount or Direct Mount  
for Square & round Poles  
65/870



Direct Mount for  
Square & Round Poles.  
65/871



Trunnion  
65/872



Yoke  
65/873 & 65/874



\*Cutoff Shield  
65/877 & 65/878

100W &  
150W



200W



*\*200W 277-480V have the same footprint  
as the 240W & 300W versions to  
accommodate the larger drivers.*

240W &  
300W



*\*2 Cutoff Shields Are Recommended for  
Double Panel Array Versions. (For more  
information on dimensions see page 14)*

# Slip-fitter & Fixed Arm Mounts with Integrated Junction Boxes & Knockouts



Fixed Arm Mount  
with Sensor  
Knockouts  
65/876

## Photocell/Socket

86/221: 120-277V - 100W/150W/200W  
86/222: 120-277V - 240W/300W  
86/223: 277-480V - All Wattages

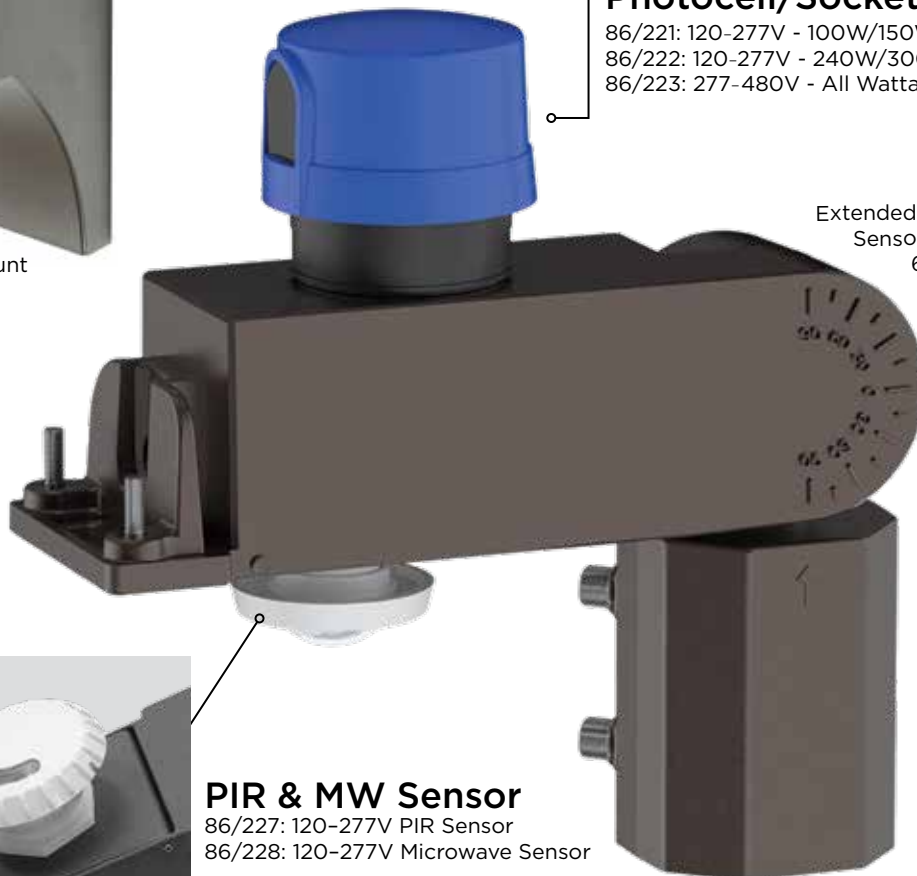

Extended Slip-Fitter with  
Sensor Knockouts  
65/875

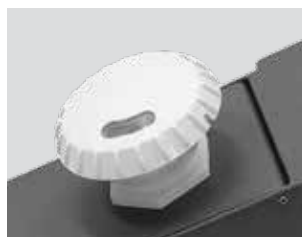

## PIR & MW Sensor

86/227: 120-277V PIR Sensor  
86/228: 120-277V Microwave Sensor

ITEM #	DESCRIPTION	FEATURE	PK
65/870	UNIVERSAL MOUNT	DIRECT & SLIP-FITTER MOUNT BRONZE	8
65/871	DIRECT MOUNT	SQUARE/ROUND POLE MOUNT BRONZE	8
65/872	TRUNNION MOUNT	BRONZE FINISH	8
65/873	YOKE MOUNT	100W/150W/200W BRONZE	8
65/874	YOKE MOUNT	240W/300W BRONZE	8
65/875	EXTENSION SLIP-FITTER	WITH SENSOR KNOCKOUTS BRONZE	8
65/876	FIXED ARM MOUNT	WITH SENSOR KNOCKOUTS BRONZE	8
65/877	CUTOFF SHIELD	BRONZE - 100W/150W/240W/300W & 200W 277-480V	8
65/878	CUTOFF SHIELD	BRONZE - 200W 120-277V	8
86/221	PHOTOCELL/SOCKET	120-277V FOR 100W/200W	50
86/222	PHOTOCELL/SOCKET	120-277V FOR 240W/300W	50
86/223	PHOTOCELL/SOCKET	277-480V	50
86/224	SURGE SUPPRESSOR	10kV - 120-277V	100
86/225	SURGE SUPPRESSOR	10kV - 277-480V	100
86/226	12-24V PIR SENSOR	277-480V	50
86/227	PIR SENSOR	120-277V	50
86/228	MICROWAVE SENSOR	120-277V	50

# Product Dimensions with Alternate Mounting Options

## 100W & 150W

A full assortment of mounting accessories to meet any applications needs.

2 3/8" Slip-Fitter (Included)

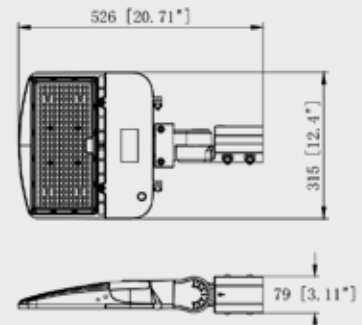
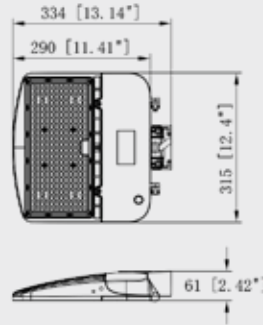

65/870  
Universal Mount

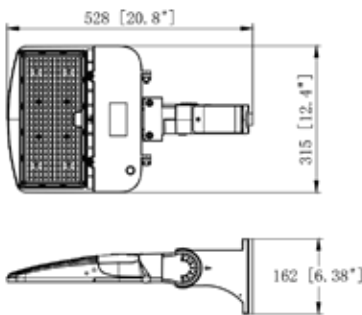

65/871  
Direct Mount

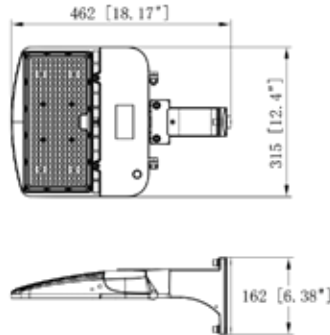

65/872  
Trunnion Mount

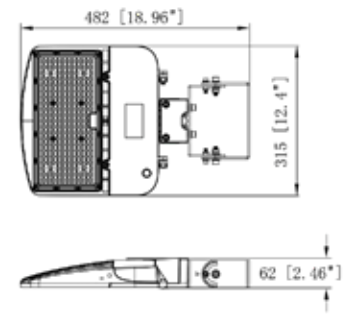

65/873  
Yoke Mount

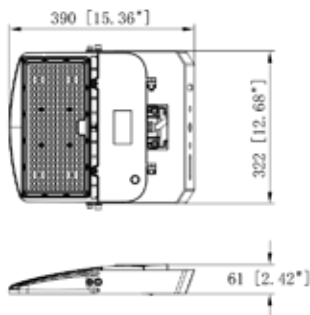

65/875  
Extended 2 3/8" Slip-Fitter with knockouts and integrated junction box.

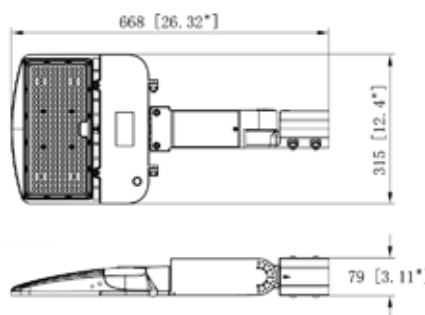

65/876  
Fixed Arm Mount with Knockouts and integrated junction box.

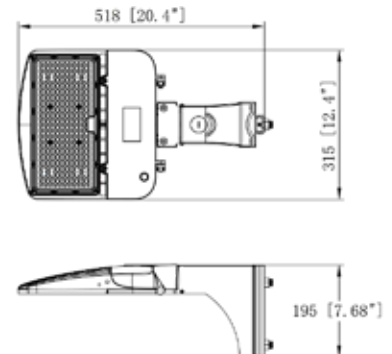

## Product Dimensions Continued

### 200W

Innovative mounting accessories with Knockouts & Integrated Junction Boxes for Greater Ease Of Installation.

\*200W 277-480V have the same footprint as the 240W & 300W Versions to accommodate the larger drivers.

#### 2 3/8" Slip-Fitter (Included)

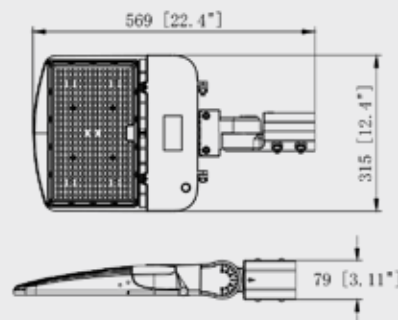
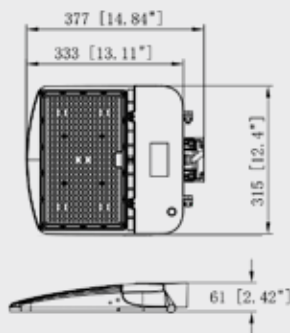

#### 65/870 Universal Mount

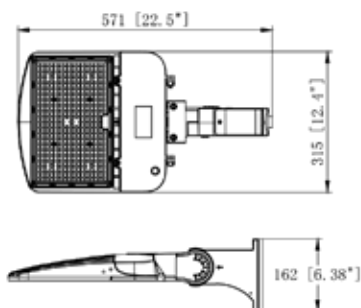

#### 65/871 Direct Mount

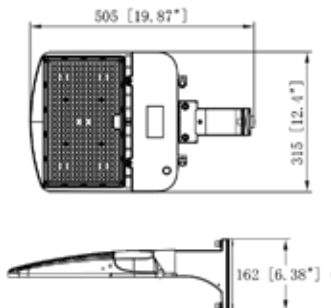

#### 65/872 Trunnion Mount

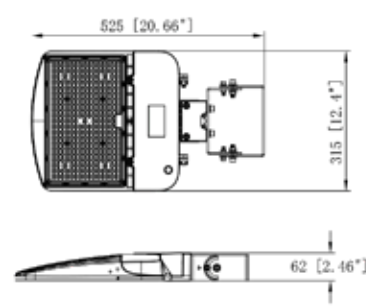

#### 65/873 Yoke Mount

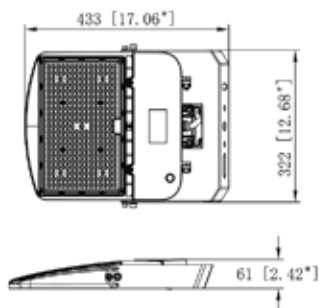

#### 65/875 Extended 2 3/8" Slip-Fitter with knockouts and integrated junction box.

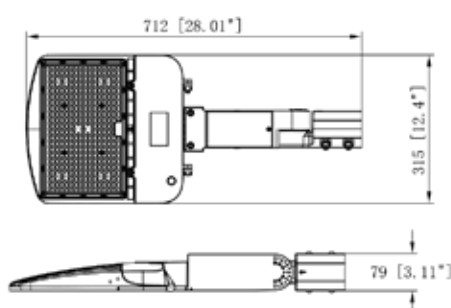

#### 65/876 Fixed Arm Mount with Knockouts and integrated junction box.

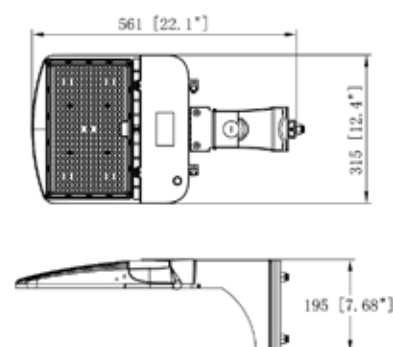

# Product Dimensions Continued

## 240W & 300W

(Also 200W 277V-480V)

Cutoff shields are also available to eliminate light trespass.

2 3/8" Slip-Fitter (Included)

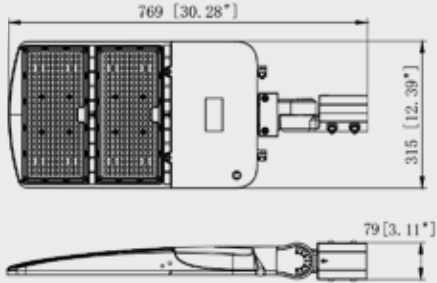
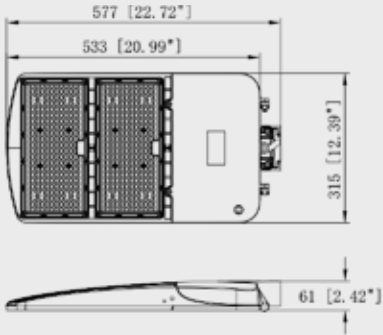

**65/870**  
Universal Mount

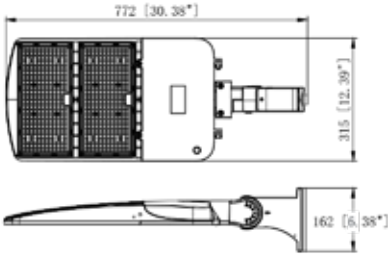

**65/871**  
Direct Mount

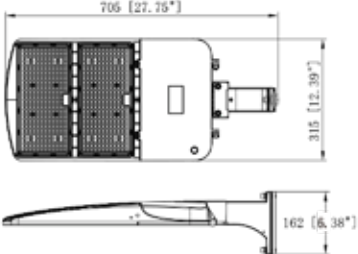

**65/872**  
Trunnion Mount

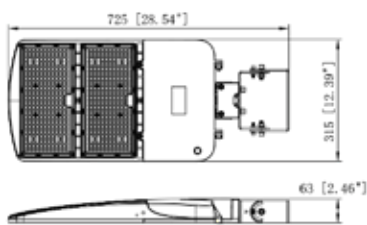

**65/874**  
Yoke Mount

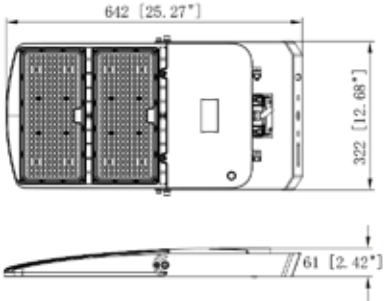

**65/875**  
Extended 2 3/8" Slip-Fitter with knockouts and integrated junction box.

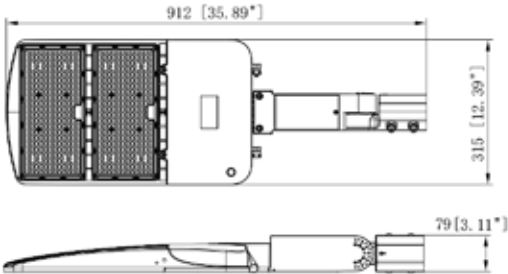

**65/876**  
Fixed Arm Mount with Knockouts and integrated junction box.

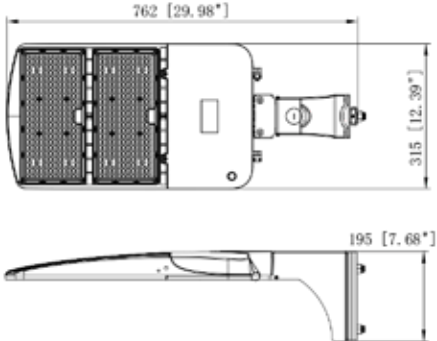



# Product Accessory Dimensions

## Cut-Off Shield

- **65-877** for 100W/150W/240W/300W and 200W 277-480V versions.
- **65-878** for use with 200W 120-277V version.

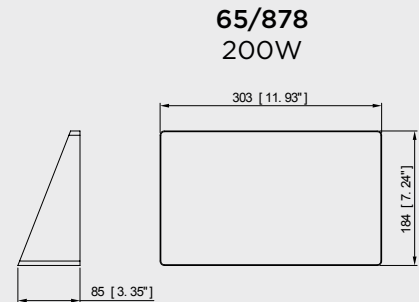
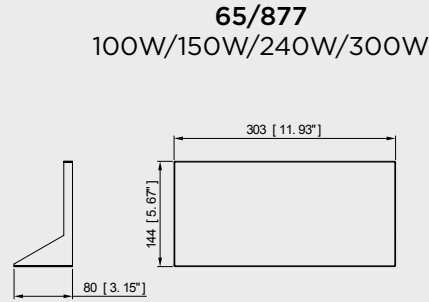

## Mounts

Included 2 3/8" Slip-Fitter

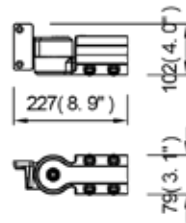

**65/870**  
Universal Mount

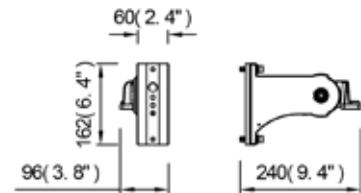

**65/871**  
Direct Mount

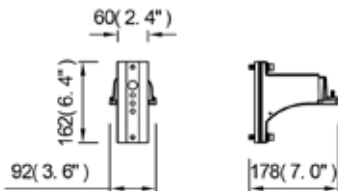

**65/872**  
Trunnion Mount

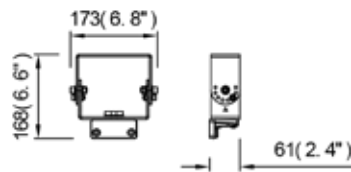

**65/873** Yoke Mount  
for use with 100W/150W/200W

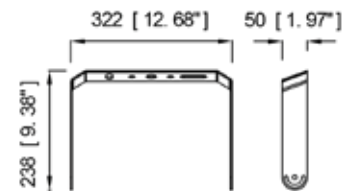

**65/874** Yoke Mount  
for use with 240W/300W

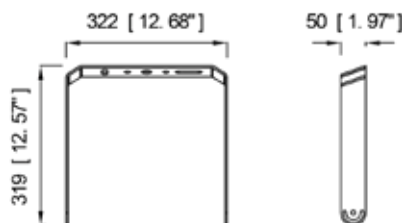

**65/875**  
Extended 2 3/8" Slip-Fitter with knockouts and integrated junction box.

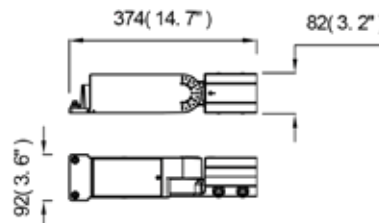

**65/876**  
Fixed Arm Mount with Knockouts and integrated junction box.

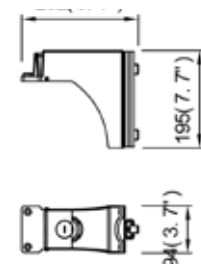



# A SINGLE SOURCE FOR YOUR LIGHTING NEEDS

We answer today's evolving lighting needs with thousands of products that offer energy efficiency, high quality illumination, value, safety and solutions through innovation and design.

SATCO manufactures thousands of lighting solutions. With products that range from LED lamps and fixtures to traditional lighting and components, stocked at the ready throughout North America, we supply the market.



## DISTRIBUTION CENTERS

### **New York (Headquarters)**

110 Heartland Blvd., Brentwood, NY 11717  
Tel. 631-243-2022, Fax: 631-243-2027

### **Texas**

2000 Valwood Parkway, Farmers Branch, TX 75234  
Tel. 972-247-2437, Fax: 972-247-5408

### **Florida**

1694 NW 215<sup>TH</sup> Street Miami Gardens, FL 33056  
Tel. 305-624-2044, Fax: 305-623-0286

### **California**

31288 San Benito Street, Hayward, CA 94544  
Tel. 510-487-4822, Fax: 510-487-8955

### **Washington**

4710 116th S.W., Mukilteo, WA 98275  
Tel. 425-789-3300, Fax: 425-789-3310

### **Puerto Rico**

Campech Street. 23 Julio  
N. Matos Industrial Park, Carolina, PR 00984  
Tel. 787-757-3510, Fax: 787-757-3540

### **Canada & Mexico**

[Internationalsales@satco.com](mailto:Internationalsales@satco.com)/631-243-2022 EXT315